

# GR12203/PC

## Technical Specifications

- Product made of polycarbonate
- Glow wire test: 850°C
- Temperature during installation -15 +60°C
- Shock resistance: Ik07
- Pressure test with sphere according to CEI23-48 70°C
- Ageing test according to CEI 23-48 7 days at 70°C
- Large entrance holes with easy breaking
- The fixing system for frame is self cleaning even in case it is full of plaster
- Suitable for embedding in concrete
- Fixing by spike or screw in the panel

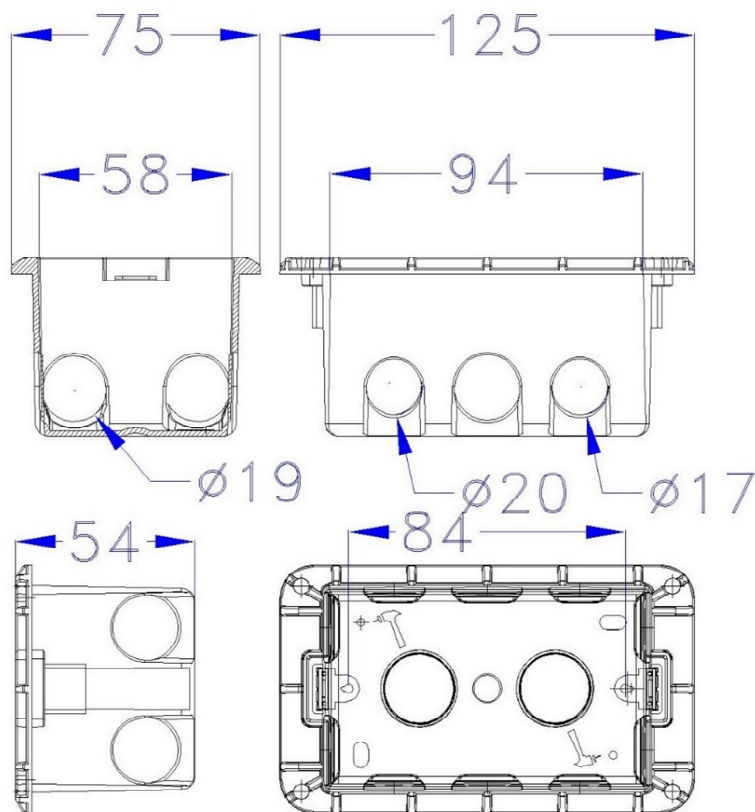

# GR12203/PC

## Specifiche Tecniche

- Prodotto in policarbonato
- Glow wire test: 850°C
- Temperatura durante l'installazione -15 +60°C
- Resistenza urto : Ik07
- Prova di pressione con sfera secondo CEI23-48 70 °
- Grandi fori di ingresso con facile rottura
- Il sistema di fissaggio del telaio è autopulente anche in caso di intonaco
- Adatta per annegamento nel cemento
- Fissaggio a chiodo o vite nel pannello

